

IPC-HDB5200

2 Megapixel Water-Proof & Vandal-Proof Network Dome Camera



Features

- 1/3" 2Megapixel progressive scan Exmor CMOS
- H.264 & MJPEG dual-stream encoding
- Max 25/30fps@1080P(1920×1080)
- DWDR, Day/Night(ICR), 3DNR, Auto iris, AWB, AGC, BLC
- Multiple network monitoring: Web viewer, CMS(DSS/PSS) & DMSS
- 2.7~12mm varifocal lens
- Built-in 1/1 alarm in/out
- Micro SD memory, IP66, IK10, PoE

Technical Specifications



Model		IPC-HDB5200P	IPC-HDB5200N
Camera			
Image Sensor		1/3" 2Megapixel Exmor CMOS	
Effective Pixels		1920(H)x1080(V)	
Scanning System		Progressive	
Electronic Shutter Speed		Auto/Manual 1/3~1/10000	Auto/Manual 1/4~1/10000
Min. Illumination		0.1lux/F1.4(color), 0.01lux/F1.4(B/W)	
S/N Ratio		More than 50db	
Video Output		1 channel BNC(1.0Vp-p, 75Ω)	
Camera Features			
Max. IR LEDs Length		N/A	
Day/Night		Auto(ICR)/Color/B/W	
Backlight Compensation		Off/BLC/HLC/DWDR	
White Balance		Auto/Manual	
Gain Control		Auto/Manual	
Noise Reduction		3D	
Privacy Masking		Up to 4 areas	
Lens			
Focal Length		2.7~12mm	
Max Aperture		F1.4	
Focus Control		Manual	
Angle of View		H: 105.6°(Wide)~27.4°(Tele)	
Lens Type		Manual/Auto Iris (DC)	
Mount Type		Board-in Type	
Video			
Compression		H.264/ MJPEG	
Resolution		1080P(1920×1080)/ D1(704×576)	1080P(1920×1080) / D1(704×480)
Frame Rate	Main Stream	1080P(1 ~ 25/30fps)	
	Sub Stream	D1(1 ~ 25/30fps)	
Bit Rate		H.264: 16K ~ 8192Kbps	
Audio			
Compression		G.711a/G.711u(64kbps)/PCM(128kbps)	
Interface		1/1 channel In/Out	
Network			
Ethernet		RJ-45 (10/100Base-T)	
Wi-Fi		N/A	
Protocol		IPv4/IPv6, HTTP, HTTPS, SSL, TCP/IP, UDP, UPnP, ICMP, IGMP, SNMP, RTSP, RTP, SMTP, NTP, DHCP, DNS, PPPOE, DDNS, FTP, IP Filter, QoS, Bonjour	
ONVIF		ONVIF Profile S	
Max. User Access		20 users	
Smart Phone		iPhone, iPad, Android, Windows Phone	
Auxiliary Interface			

Memory Slot	Micro SD, Max 32GB
RS485	N/A
Alarm	1/1 channel In/Out
PIR Sensor Range	N/A
General	
Power Supply	AC24V/DC12V, PoE(802.3af)
Power Consumption	<5W
Working Environment	-20°C~+60°C, Less than 90% RH
Ingress Protection	IK10
Vandal Resistance	IP66
Dimensions	Φ151mm×119mm
Weight	1.25kg

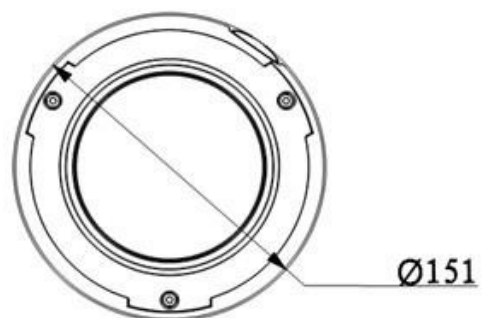
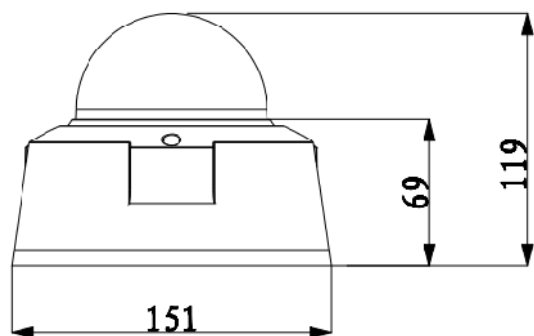
Dimensions (mm)

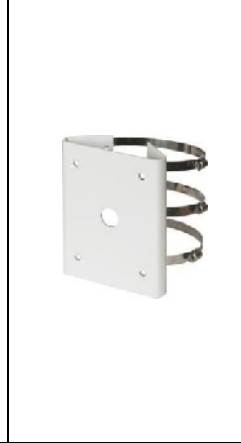
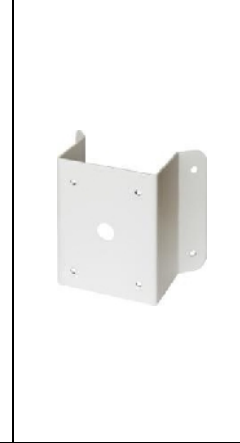

Accessories (optional)

				
PFA100	PFB300S	PFA120	DH-65FQ	DH-65FW